



ATTACHMENTS

HC16-Hydra Clip



1300 East 3rd Street Coffeyville Kansas 67337

Phone: (620) 251-8500

www.treeshear.com

Table of Contents

1. Cover Page
2. Blank
3. Table of Contents
4. Serial Number Information
5. Introduction
6. Operating Instructions
7. Operating Instructions continued
8. Exploded Assembly Diagram
9. Part Number Detail Sheet
10. Specifications
11. Lubricating Instructions
12. Blade Adjustment
13. Bolt Maintenance Schedule
14. Shear Blade Conditioning
15. Warranty Information
16. Warranty Information continued

Serial Number Information

Please take time to record the serial number, dealer name, and date of purchase. The serial number is stamped into the top of the hitch plate. It will be a number similar to this example. *HCH259999*

Tree Shear Serial Number _____

Dealer Name _____

Date Purchased _____

INTRODUCTION

CONGRATULATIONS on purchasing the very best engineered and manufactured tree shear on the market today.

M&M Attachments policy is one of continuous improvement. The right to change prices, specifications or design, at any time without notice is reserved.

All data given in this book is subject to production variations. Dimensions and weights are approximate only and the illustrations do not necessarily show shears exactly as they are. For exact information about any particular shear consult your local dealer.

The following instructions will answer most of your questions regarding the M&M **HYDRA-CLIP** tree shear. However, if you have any questions please call your local dealer or WEBER MANUFACTURING, LLC at (620) 251-8500.

Operating Instructions

IMPORTANT

Read and understand the following before operating the tree shear.

Because of the possible severity of injury to persons or property from accidents, which may result from the improper use of this equipment, it is important that correct procedures are followed and common sense is exercised.

Inspections should be made on a regular basis upon installation of the machine and operational procedures specified in this manual should be followed to assure safe operation under prevailing conditions.

1. This unit is a precision piece of power equipment, therefore exercise extreme caution at all times.
2. Know the controls and how to stop the machine quickly.
3. Cutting trees, especially large ones, requires absolute attention. Take a moment on each and every tree to study how the tree will fall, what direction is the wind blowing and what way would the tree fall naturally?
4. Never cut a tree that is leaning towards the operator or machine or one that is leaning in such a way that it might fall on the machine or tip the machine over.
5. Never cut trees that are in direct contact with power lines or their path of fall will come in contact with power lines.
6. Never cut trees that are on a steep enough grade that you cannot safely use your machine and always reduce speeds on steeper grades.
7. Never cut trees that are close enough to water that they could turn your machine into the water.

Continued on next page

8. **Never cut trees any higher than ground level!!! Serious injury or death can occur from overturning due to limited loader capacity!!! Always cut trees at ground level!!!**
9. Inspect hoses for bear spots or cuts and replace if found. Hot hydraulic oil can cause serious injury.
10. To prevent serious injury never close shear blades on or close to someone.
11. Do not allow children to operate this machine. Do not allow adults to operate this machine without proper instruction.
12. To maintain control of the shear and reduce the possibility of upset to the skid loader or damage to shear, operate the machine smoothly, avoiding erratic operation and excessive speed.
13. Keep the area of operation clear of all persons, particularly small children and pets.

HYDRA-CLIP ASSEMBLY DIAGRAM

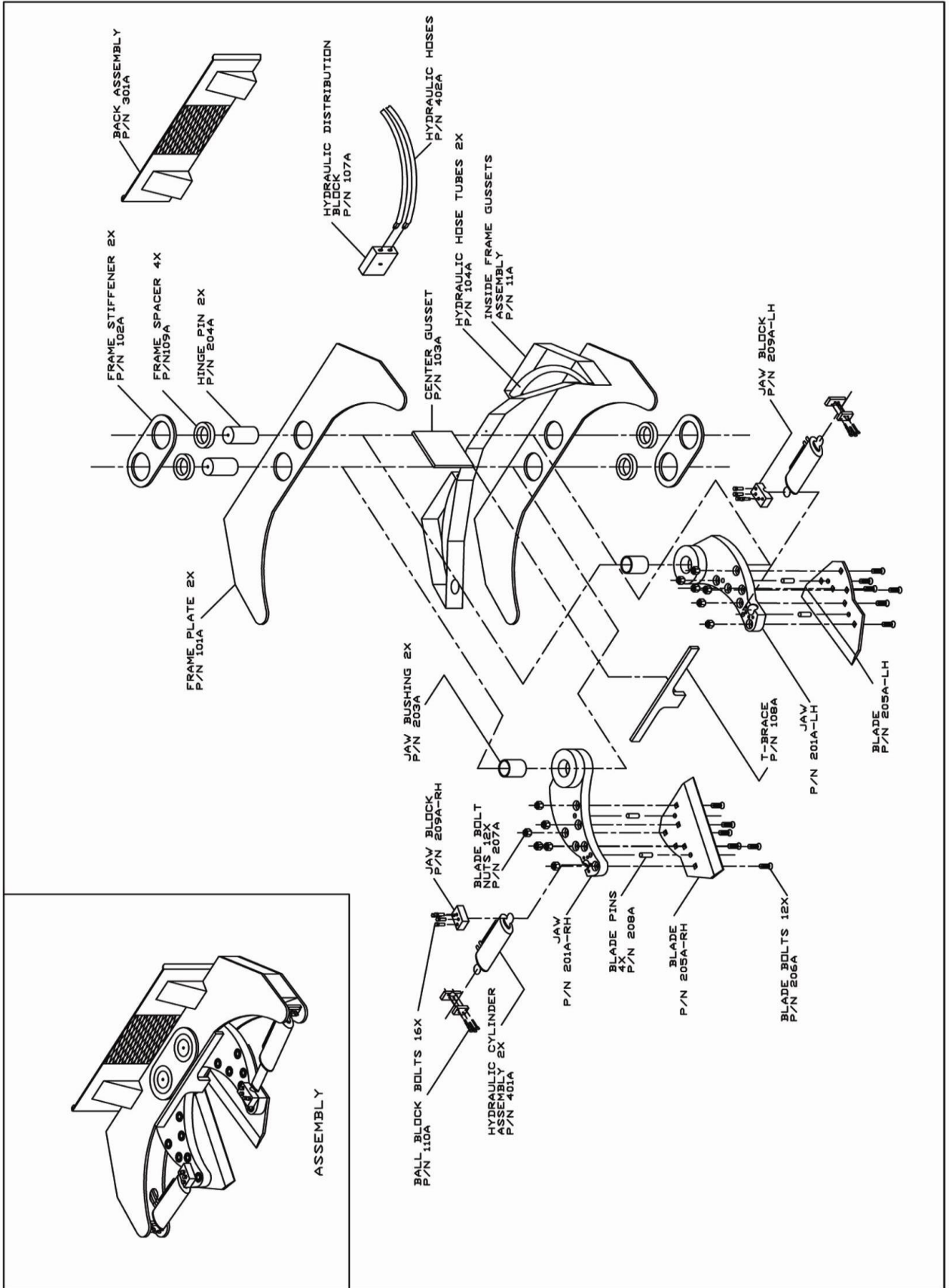

Hydra Clip Part Number List

	Item Description	Part Number
100's	Frame Plate	101A
	Frame Stiffener	102A
	Center Gusset	103A
	Hydraulic Hose Tubes	104A
	Stationary Outer Ball Blocks	105A
	Removable Outer Ball Blocks	106A
	Hydraulic Distribution Block	107A
	T-Brace	108A
	Frame Spacer	109A
	Ball Block Bolts	110A
	Inside Frame Gussets Assembly	111A

200's	Jaw (right)	201A-RH
	Jaw (left)	201A-LH
	Jaw Spacer	202A
	Jaw Bushing	203A
	Hinge Pin	204A
	Blade (right)	205A-RH
	Blade (left)	205A-LH
	Blade Bolts	1"-8 x 4" Plow Bolt
	Blade Bolt Nuts	1"-8 Gr8 Hex Nut
	Blade Pin	208A
	Jaw Ball Block (left)	209A-LH
	Jaw Ball Block (right)	209A-RH

300's	Back Assembly	301A
--------------	---------------	------

400's	Hydraulic Cylinder Assembly	HC-401D
	Hydraulic Hoses (3/8"x45" nptf)	Pt# (#6)

Specifications

Total weight	1725 lbs
Total weight w/Tree Grapple	2150 lbs
Frame width	76 inches
Frame height	6 inches
Overall height	22 inches
Overall height w/Tree Grapple	52 inches
Blade length	24.25 inches
Blade width	16.25 inches
Cutting capacity	16 inches
Frame	3/4" High Carbon Steel
Jaws	3" Solid Steel
Shear Cylinders	5" Welded w/3" Chrome Shaft
Blades	1" Hardox 450 Steel
Grapple Cylinder	2" Welded w/1-1/2" Shaft
Grapple Arms	3/4" High Carbon Steel
Grapple Frame	2-1/2" Heavy Wall Tubing

Hydraulics

Supply lines to skid steer or tractor
 Hoses from distribution block to cylinders
 Supply lines to Tree Grapple

1/2 inch (Hose #5)
 3/8 inch (Hose #6-1)
 3/8 inch (Hose #24-1)



Lubricating Instructions

There are six (6) grease fittings on the tree shear, and two (2) on the tree grapple. Two (2) are located in the main hinge pins directly on top in the middle of the machine. One (1) at each end of the hydraulic cylinder rams in the ball and socket swivels, and one (1) at each end of the tree grapple cylinder. Lastly, one (1) in each of the two (2) main grapple hinge pins. All of the greasing points are clearly marked with a grease decal when the machine is new.

Every three to four hours of operation all of these fittings should be greased with a high temperature high pressure grease. This will insure grease has completely worked into every area of friction resulting in longer machine life.

GREASE MACHINE TWICE DAILY

After break-in period all ball and socket swivels should be greased until grease exits from the visible openings and main hinge pins should be greased approximately 10-15 pumps of the grease gun.

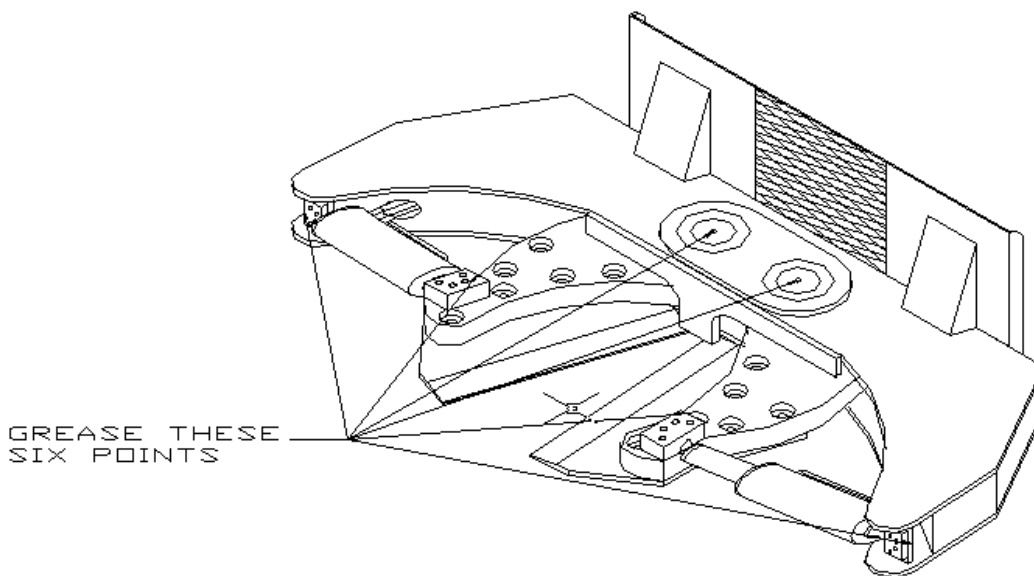

NOTE: Failure to properly lubricate as recommended will result in gauling of parts and will not be covered under warranty. It is normal for main hinge pins to take grease slowly when machine is new due to tight tolerances in pins.

Blade Adjustment

HYDRA-CLIP

Instructions for adjusting the blades when normal wear has created a gap and during the break in period.

1. Remove the four bolts holding the ball retaining plate to jaw.
2. Using a spanner wrench on the cylinder ram (provided) and a spanner wrench or pipe wrench on the ball shoulder unscrew the ball out of the end of the cylinder shaft. (See diagram below)
3. The amount of spacer or washer thickness needed depends upon the amount of gap in the blades. Measure the thickness of gap approximately 6 inches in from the tip of the blades. Insert spacer(s) as shown in diagram below on the ball threads. Example: if you have 1/8" gap, use one 1/16" thick spacer on each ball to equal the 1/8" gap in blades or use one 1/8" washer in only one of the two sides. It is important that only enough washer or spacer is used to equal the total gap thickness.
4. Tighten ball against spacer and ram very snugly.
5. Align the ball(s) back into the ball seat(s) and reinstall the retaining bolts into the jaw. (See bolt maintenance schedule for torque specifications)

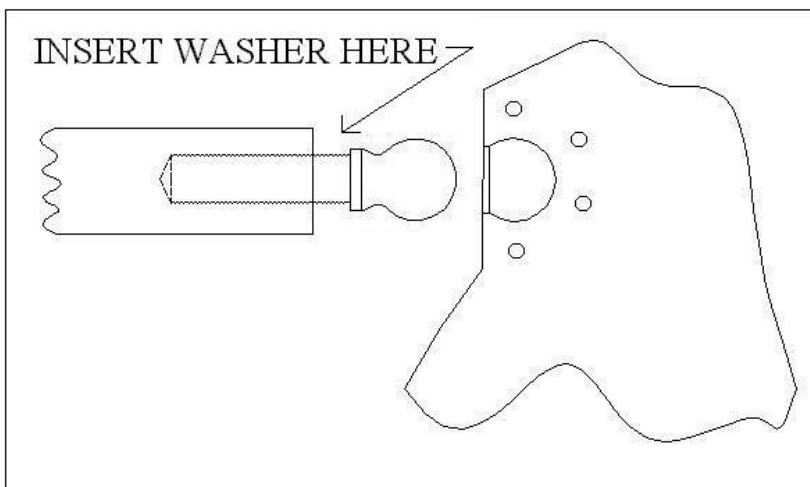

NOTE: Never allow balls to run loose or unscrewed as severe machine damage could occur. Check at each grease interval for this condition. Apply anti seize to threads on rod end balls at least once a year.

Maintenance

All tree shears run under tremendous pressures and cause great strains on blade and cylinder retaining bolts. To maintain the machine, bolts will require periodic tightening. During the first few hours of operation the machine will have a break in period, so all bolts should be checked periodically during this time as some stretching may occur in the bolts.

After one hour of running time the machine bolts should be re-torqued to the following specifications to insure proper machine usage.

IMPORTANT: Apply anti seize to threads on cylinder rod end balls once a year.

Blade Bolts	<i>250 ft/lbs</i>
Cylinder Ram Retaining Bolts	<i>125 ft/lbs</i>

NOTE: It is normal for some loosening of the bolts to occur as the machine goes through its break in period. It is important to check all bolts several times during the first few hours of operation.

The break in period of the tree shear will be approximately the first 3 hours of operation. It is normal to need to adjust the blades during this period. After the break in period the blades will only need to be adjusted as normal blade wear occurs. (See blade adjustment page 11)

It is not necessary to adjust the tree grapple. The hydraulic pressure reducer is adjustable to allow the force of the grapple to be reduced if desired.

Shear Blade Reconditioning

M&M tree shear blade shape is designed for maximum shearing force to be transmitted from the machine to the tree at the lowest possible position. However if a blade should become worn, (it was manufactured to be reconditioned) maintaining this factory angle is very important to the efficiency of your tree shear. Any chips or gouges in the metal can be arc welded or wire welded with 70,000-lb. tensile strength rod or wire. The full-scale drawing below can be transferred to a cardboard template and then be used as a guide for sharpening your shear's blades.

~FULL SCALE~

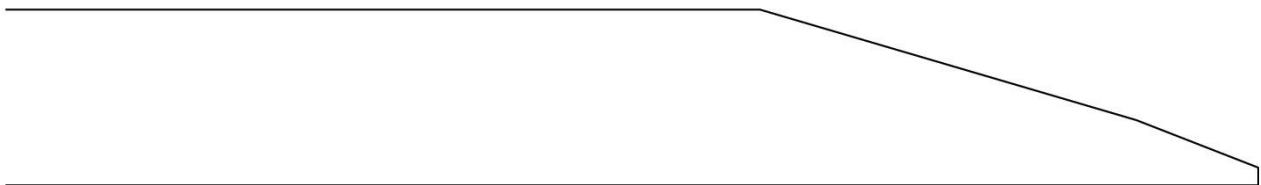

LIMITED WARRANTY AND TERMS OF SALE

WARRANTY: WEBER MANUFACTURING, LLC products are warranted to the original retail purchaser against defects in material and workmanship which occur within twelve (12) months from the date of delivery to the purchase, or the date of delivery to the carrier in the case of F.O.B. shipments. WEBER MANUFACTURING, LLC's warranty shall be limited, at WEBER MANUFACTURING, LLC's option, to repair or replace any defective parts or components. Such repair or replacement shall be the purchaser's sole and exclusive remedy hereunder. Expendable components are excluded from this warranty. Normal wear and tear, along with routine maintenance, is always excluded from this warranty. Purchaser shall pay all transportation costs associated with request for warranty service, including costs and expenses of transporting the product or component part to WEBER MANUFACTURING, LLC service centers. Warranty service shall be performed by the WEBER MANUFACTURING, LLC dealer from whom the product was purchased, in the dealer's service department, during regularly scheduled hours of operation.

WARRANTY VOIDED BY MODIFICATION, ALTERATION OR MISUSE: This warranty is void if [1] the product is modified or altered in any way not approved in advance and in writing by WEBER MANUFACTURING, LLC, [2] if other than genuine WEBER MANUFACTURING, LLC parts have been installed, or [3] the product or its components have been subjected to misuse, neglect, accident, damage, improper maintenance, or improper operation.

LIABILITY LIMIT: WEBER MANUFACTURING, LLC shall not be liable in contract, tort, or otherwise, for any special, indirect, incidental or consequential damages, such as, but not limited to, loss of profits, loss of production, or from injury or damage caused by reason of the installation, modification, use, repair, maintenance, diagnostics, or mechanical failure of a WEBER MANUFACTURING, LLC product. WEBER MANUFACTURING, LLC shall not be liable for any cost incurred related to assessing, analyzing, or diagnosing to, or defect in, any product, regardless of whether it is a WEBER MANUFACTURING, LLC product or the product of another manufacturer, vendor or other third party. WEBER MANUFACTURING, LLC's warranties hereunder extend only to the direct customer of WEBER MANUFACTURING, LLC [or to the first user of the product if the direct customer purchases solely for the purpose of resale]. WEBER MANUFACTURING, LLC makes no warranties when the damage results from the failure to read, understand or follow all instructions in the operator's manual(s) and the equipment warning decals. The purchaser, or user of any WEBER MANUFACTURING, LLC equipment shall be responsible for all ordinary maintenance, adjustments, and cleaning of the product. In the event that the WEBER MANUFACTURING, LLC product is not properly maintained, all warranties by WEBER MANUFACTURING, LLC are null and void. Certain component parts of WEBER MANUFACTURING, LLC products are purchased from other

vendors. WEBER MANUFACTURING, LLC warrants these component parts only to the extent of the vendor's warranties. WEBER MANUFACTURING, LLC shall repair or replace such component parts in accordance with the vendor's warranty policy only if WEBER MANUFACTURING, LLC, in its sole discretion, determines such component parts to be defective.

ASSUMPTION OF RISK: Purchaser, and any subsequent user, assumes the risk of, and liability for, all loss, damage, or injury to persons or property caused by misuse of WEBER MANUFACTURING, LLC products. Misuse includes the failure to read, understand, or follow all instructions in the operator's manual(s) and the equipment warning decals.

WARRANTY DISCLAIMER: To the maximum extent permitted by applicable law, WEBER MANUFACTURING, LLC makes no warranties other than those stated herein, and these warranties are expressly in lieu of all other warranties, whether expressed or implied, including by way of example and not by way of limitation, any warranties of merchantability or fitness for a particular purpose, and also in lieu of any other obligations on the part of WEBER MANUFACTURING, LLC. During the period of the warranty, the exclusive remedy is repair or replacement of the product.

MODIFICATIONS: No representation or warranty, expressed or implied, made by any sales representative, or any agent or employee of WEBER MANUFACTURING, LLC which is not specifically set forth herein shall be binding on WEBER MANUFACTURING, LLC unless approved in writing by an authorized representative of WEBER MANUFACTURING, LLC.

TAXES: Unless otherwise noted, the price does not include any state or local, property, sales, use, or privilege tax or license. If any such charge shall be assessed because of, or in connections with, the transaction described herein, the purchaser agrees to pay the same or reimburse WEBER MANUFACTURING, LLC as the case may be.

LOSS OR DAMAGE IN TRANSIT: Any claim against WEBER MANUFACTURING, LLC for loss or damage to products in transit shall be handled as follows: Immediately upon delivery, purchaser must inspect product for damage. If damage is detected or suspected, purchaser must notify the carrier (by writing on the bill of lading – at the time of delivery) and must also notify WEBER MANUFACTURING, LLC within one [1] day of delivery (by phone call, email or letter) of any damage sustained to product. All RISK OF LOSS for damage in transit passes to purchaser upon acceptance of delivery, and any failure on the part of the purchaser to detect damage and/or failure to strictly adhere to the foregoing notification requirements shall constitute a waiver of claim and shall transfer all RISK OF LOSS to purchaser.

GENERAL PROVISION: The failure of WEBER MANUFACTURING, LLC to enforce any right will not be construed as waiver of WEBER MANUFACTURING, LLC's right to enforce performance in the future. The purchaser may not assign any rights or delegate any performance hereunder without the express written consent of WEBER MANUFACTURING, LLC.

CLAIM/NOTICE OF DEFECTS: In the event the purchaser claims that a WEBER MANUFACTURING, LLC product is defective, WEBER MANUFACTURING, LLC shall be given an equal opportunity for inspection, or, upon request, shall be furnished a sample of such product. Any claim must be made within thirty [30] days after receiving the product shipped hereunder. The purchaser shall set aside, protect, and hold such product without further processing until WEBER MANUFACTURING, LLC has an opportunity to inspect and advise the purchaser as to the disposition, if any, to be made of such product. In no event shall any WEBER MANUFACTURING, LLC product be returned, reworked, or scrapped by the purchaser without the express written authorization of WEBER MANUFACTURING, LLC.

PATENT RIGHTS: The purchaser agrees not to violate or infringe the patent rights relating to any WEBER MANUFACTURING, LLC product, or any other patent rights under the control of WEBER MANUFACTURING, LLC under which WEBER MANUFACTURING, LLC has the right to manufacture or sell. The purchaser also agrees not to contest WEBER MANUFACTURING, LLC's title to any and all such patent rights, nor the validity or scope thereof. The purchaser assumes liability for patent or copyright infringement when goods or products are made to the purchaser's specifications.

NON-INCORPORATION: Any terms consistent with those stated herein which may appear in the purchaser's formal order, or in any proposal for additional or different terms, or any attempts by the purchaser to vary in any degree, any of the terms of this offer, are hereby objected to and rejected, but such proposal shall not operate as a rejection of this offer unless such variances in the terms and the description, quantity, price or delivery schedule of the goods or products are deemed a material alteration hereof, in which event this offer shall be deemed accepted by the purchaser without said additional, or different terms.

GOVERNING LAW, JURISDICTION AND VENUE: All disputes arising out of this limited warranty and terms of sale shall be governed by the laws of the State of Kansas. The purchaser consents to the personal jurisdiction of federal and state courts in the State of Kansas, waives any argument that such a forum is not convenient, and agrees that any litigation relating to this limited warranty and terms of sale shall be held in District Court of Montgomery County, Kansas or the Federal District Court covering southeast Kansas.

SEVERABILITY: If for any reason any one or more provisions contained in this Limited Warranty and Terms of Sale are deemed to be invalid or unenforceable, the Agreement shall be construed as if it did not contain the invalid or unenforceable provision and the rights and obligations of the Parties shall be construed and enforced accordingly.